

Basic device AED9101D



AED9101D

Basic device for AD103C



AD103C amplifier board

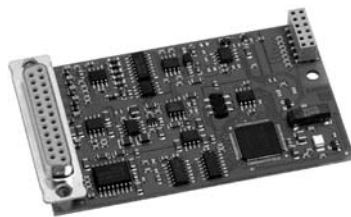

Special features

- For static and dynamic applications
- RS-232, RS-422 or RS-485 interfaces
- Test report available for 10,000 digits, class III
- Trigger input
- 10 ... 30 V supply voltage range
- Degree of protection IP65
- EMC protection
- Diagnostic bus for analysis and additional display

Dimensions (in mm; 1 mm = 0.03937 inches)

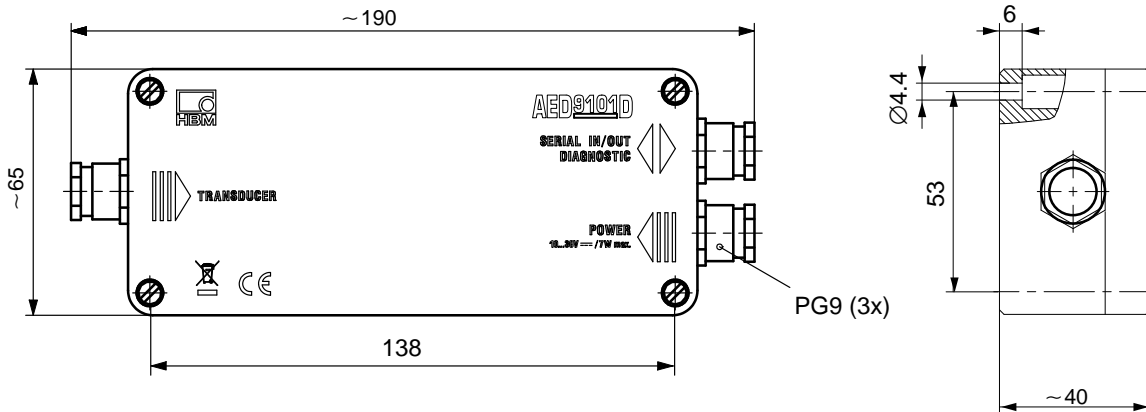

Specifications

Type		AED9101D
Measuring amplifier		AD103C
Measurement signal input	mV/V	±3, nominal ±2
Transducer connection:		
SG transducer (full bridge)	Ω	40 ... 4000
Transducer connection type		6-wire circuit
Length of transducer cable	m	≤ 100
Bridge excitation voltage	V _{DC}	5
Interfaces:		
Hardware (selected by slide-switch)		RS-232, RS-422, RS-485
Length of communications cable RS-232	m	≤ 15
RS-422, RS-485	m	≤ 1000
Max. number of bus nodes (RS-485)		32
Diagnosis bus (RS-485 2-wire)		
Protocol		ASCII/binary
Baud rate, max.	kbit/s	38.4
Node address		0 ... 89
Length of communications cable, max.	m	1000
Trigger input		
Input voltage range, LOW	V	0 ... 1
Input voltage range, HIGH	V	2 ... 30
Input voltage range at High level = 30 V	mA	< 3
Power supply:		
Supply voltage	V _{DC}	10 ... 30
Current consumption (without load cell)	mA	≤ 100 ¹⁾
Temperature range:		
Nominal (rated) temperature	°C	-10 ... +40
Operating temperature		-20 ... +60
Storage temperature		-25 ... +85
Dimensions	mm	190 x 65 x 40
Weight, approx.	g	440 (without AD10x)
Degree of protection per EN 60529 (IEC 529)		IP65

1) Current consumption $\leq 100 \text{ mA} + \frac{\text{Excitation voltage } U_B = 5 \text{ V}}{\text{Bridge resistance } R_B}$

Product numbers

1-AED9101D = Basic device **AED9101D**

1-AD103C = Amplifier board **AD103C** (see separate data sheet)

Accessories, to be ordered separately

Legal-for-trade digital scale display (see separate data sheet)

1-DWS2103

Documentation

1-FIT-AED-DOC (CD-ROM with operating manual and AED panel program AED_Panel32)

Subject to modifications.

All product descriptions are for general information only. They are not to be understood as a guarantee of quality or durability.

Hottinger Baldwin Messtechnik GmbH

Im Tiefen See 45 · 64293 Darmstadt · Germany
 Tel. +49 6151 803-0 · Fax: +49 6151 803-9100
 Email: info@hbm.com · www.hbm.com

measure and predict with confidence

